

# The Daily Edition

50¢

Serving Loudon, Monroe and Surrounding Counties

Monday, May 9, 2016

## Meth, cocaine, pills and gun found on sleeping driver

Lester Foster, 49, Craft Springs Afton, TN. was charged with Man/Sell/Del/Resale Sch. II x2, IV, Poss. of Drug Para, Possession of a Firearm, and Simple Possession x2. Deputy Jamie Ketner LCSO, observed a Dodge vehicle parked on the I-75 North Bound 68 exit ramp. The vehicle had its emergency light on and was running. Deputy pulled behind the vehicle and acti-

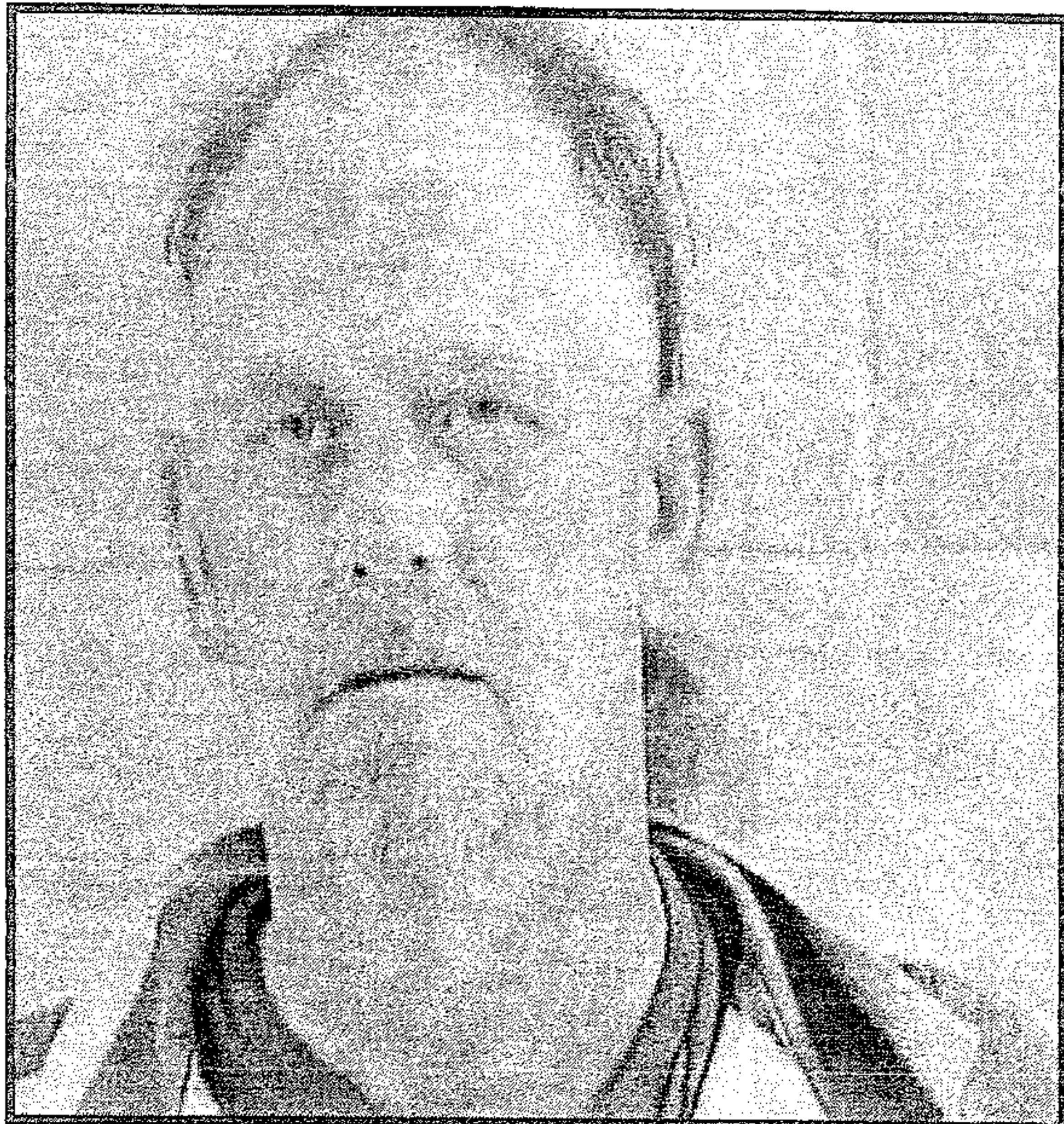

Lester Foster

(see busted pg. 2)

## Busted with a BIG Bag in speeding stop



Donte Thomason

Deante Childress

(see stop pg. 5)

## Project Lifesaver Training Exercise

Location of Incident: Greenback Fire Station 1, Morganton Road

There will be Project Lifesaver Training Exercises from 6 PM – 8 PM on Thursday, May 12, 2016.

The training will involve certified trackers from the Loudon County Sheriff's Officer, Greenback Fire, Loudon County Fire Rescue, City of Loudon Fire Department, Lenoir City Fire Department, and all Project Lifesaver members and volunteers  
(see Lifesaver pg. 8)

## Violent Criminal Apprehension Program

Part 2: The Highway Serial Killings Initiative

If there is such a thing as an ideal profession for a serial killer, it may well be as a long-haul truck driver.

FBI Crime Analyst Christie Palazzolo is quick to point out that long-haul trucking is an honorable profession and that the overwhelming majority of drivers are not murderers—but it does happen, and the pattern is

(see VCAP pg. 4)

## The old drugs in the bum trick fails Again!



Bradley Buscher

(see bum pg. 3)

### Verse of the Day

"I am the LORD your God, who brought you out of Egypt, out of the land of slavery. You shall have no other gods before me."  
— Deuteronomy 5:6-7

### Obituaries

see inside

### Wazzup

The Annual Highway 11 Yard Sale begins this week it starts in Meridian Mississippi and goes all the way to Bristol Virginia! Get Out and Grab Some Treasures!

### Weather

Today: Overcast. High 84F.  
Tonight: Cloudy skies early will become partly cloudy later at night. Low 61F.  
Tuesday Partly to mostly cloudy. High 83F.  
Tuesday Night Partial

cloudiness early, with scattered showers and thunderstorms later during the night. Low 62F.  
**Horoscopes**  
Taurus 4/20-5/20  
A convergence of unrelated circumstances requires you  
(Continued on page 6)



**busted**

uated his lights. Deputy approached the vehicle, and the driver appeared to be asleep. Deputy woke the driver and noticed he was sweating and was lethargic. While Deputy was speaking with the driver he noticed a green baggy which is consistence with drug use. Deputy ask the drive to exit the vehicle , and

identified him as Lester Foster. Mr. Foster was unaware of where he was and where he was coming from. Mr. Foster gave Deputy consent to search his person and vehicle. Mr. Foster had a large amount of money on his person, and stated he was unemployed. Deputy picked up the green baggy that he noticed and it had a crystal substance in it. Cpl. Chris Hutchens,

and Deputy Kevin Dailey arrived on scene. Cpl. Hutchens, did deploy his partner K9 Dante, who did alert to the vehicle. The following items were located: 17 1/2 1mg and 2 2mg Alprozolam, 2 Hydrocodone, 3 Diazepam,

1 gram of a crystal substance and 2 grams of a white powder. Also located was a S&W gun, meth pipe, and a Otter Box. The crystal and powder tested positive for Meth and Cocaine. Deputy Jamie Ketner LCSO, made the arrest.

Notice: The Daily Edition does not knowingly accept fraudulent or misleading materials. The Daily Edition cannot guarantee the validity of offerings or statements contained herein. All liability for the contents of all advertising, and for any claims that may arise therefrom, is the responsibility of the advertiser or its agency. The Daily Edition reserves the right to reject, edit, or abbreviate any advertisement submitted. Advertising is accepted with the understanding that all liability for all copyright violations is the sole responsibility of the advertiser. Photographs, artwork and other copy submitted for publication is considered the sole property of the advertiser. The Daily Edition will make every effort but will not be liable for failure to publish and ad or for typographical and layout errors. All statements and information about highlights featured items, letters to the editor, herein are those solely given to the interviewer or writer and the Daily Edition assumes no responsibility of the accuracy or validity thereof. The Daily Edition will gladly reprint at no charge that part of an advertisement in which an error occurs provided a claim is made within 3 days of the first publication of the ad. Information contained in the Wazzup is received anonymously and the Daily Edition assumes no responsibility for information and reserves the right to edit or reject any and/or all submissions. The Daily Edition is a daily newspaper of general circulation in Loudon County defined under TCA 2-1-104(a)(13). The Daily Edition also serves Monroe, Knox, Anderson, Roane and Blount counties and serves 30,000 readers weekly. Send mail to PO Box 1240, Lenoir City TN 37771. 865-771-2249. email: dan1204us@yahoo.com The Daily Edition is Loudon County's premier public interest and paid advertising paper. The Daily Edition is produced and published daily Monday through Friday and is circulated throughout Loudon County and parts of Monroe and Knox Counties. Display advertising rates \$5.00 per column inch and quantity discounts available. Call for information on upcoming promotions and events.



**HACIENDA Ayala's**  
**Mexican Restaurant**  
 Market Dr. \* Lenoir City (In Front of Food City)

**Real Authentic Mexican Food at Affordable Prices**

**BEST**  
**MARGARITA**



**You've Tried The Rest  
 Now Come Have The Best!!!**

**We Accept ALL Competitors Coupons Outside of Mexico City!**  
 986-3553

**Good Credit OK • Bad Credit OK • Bankruptcies OK • Repo OK**

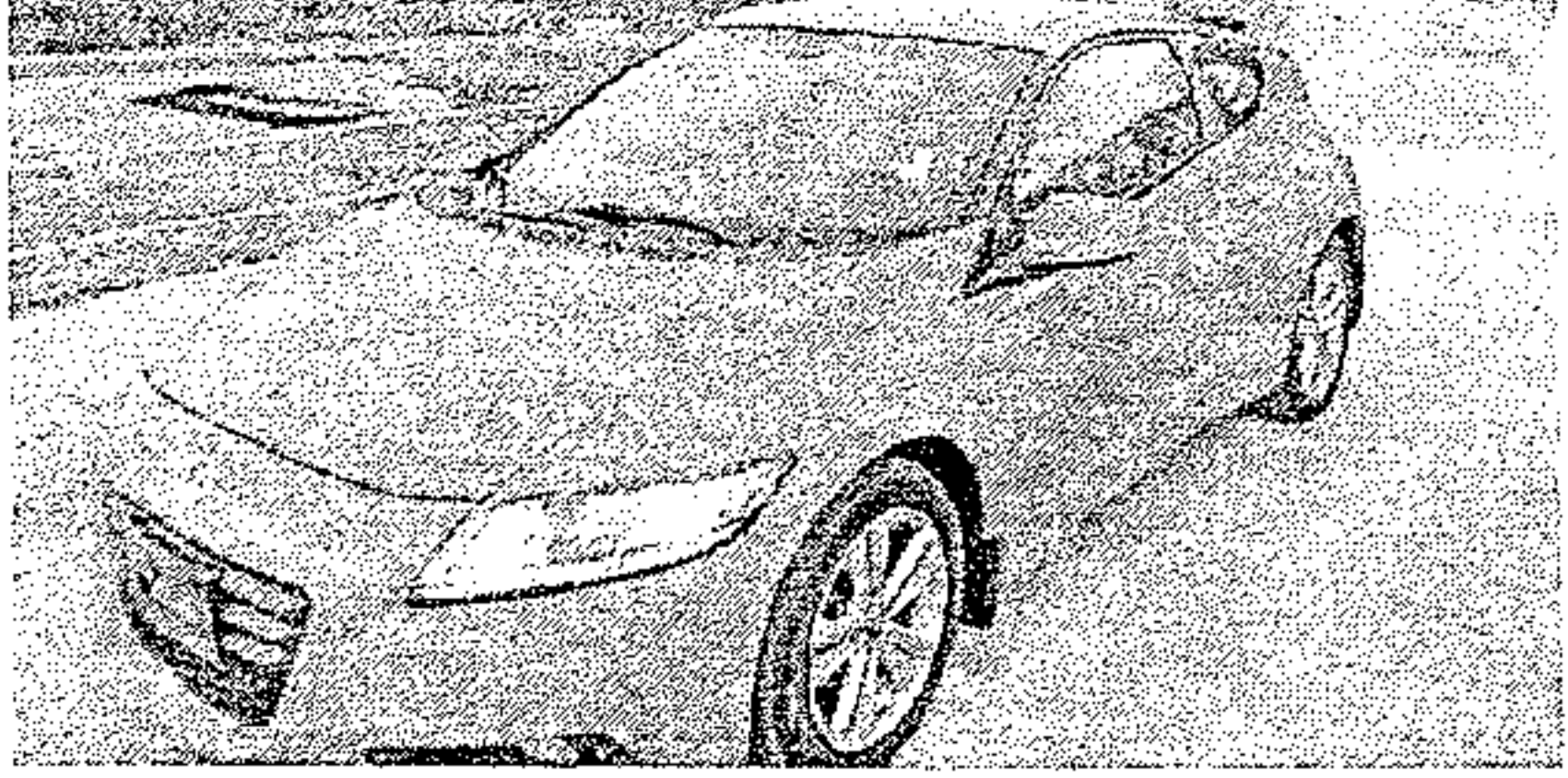

**2011 Honda CR-Z Low Miles, Like New, PW, PL, 6 SPD, Hybrid, Gas Saver**

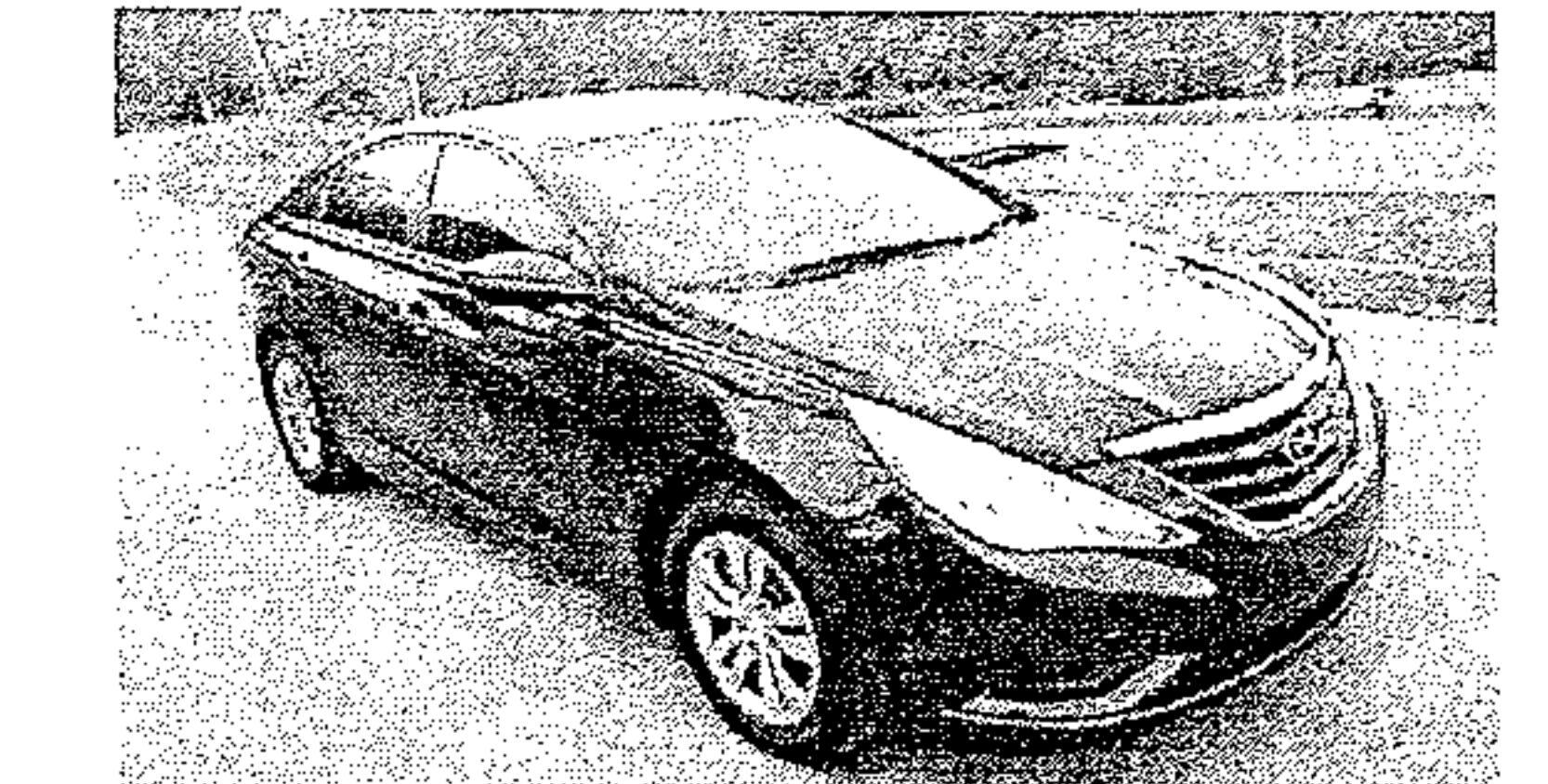

**2012 Hyundai Sonata Great On Gas, A/C, PW, PL, Tilt Wheel, Keyless Entry, Like New**

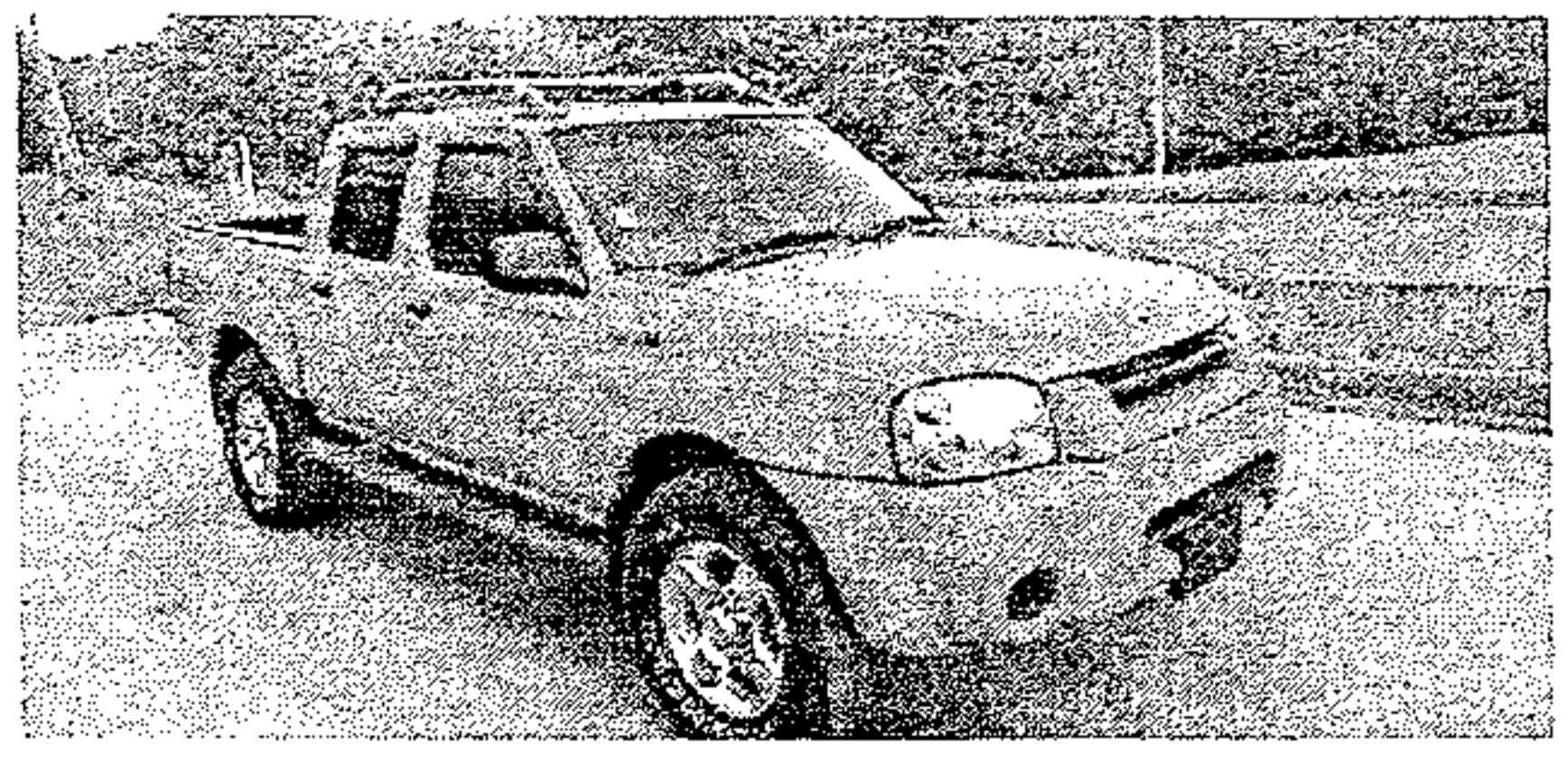

**2002 Nissan Frontier 4x4, Low Miles, A/C, Luggage Rack, Quad Cab, PW, PL**

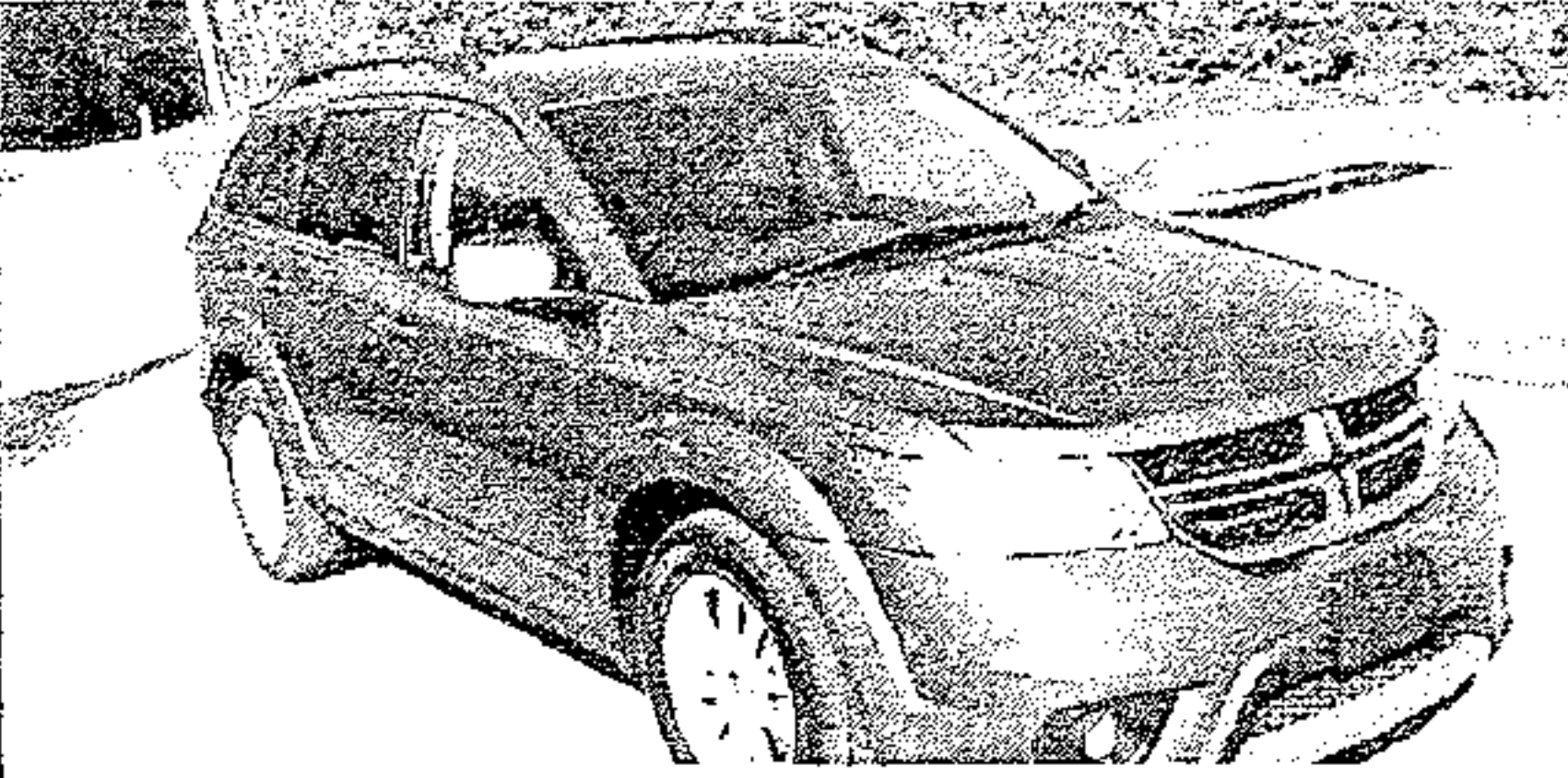

**2013 Dodge Journey 3rd Row Seat, Luxurious, Climate Control Temp, Low Miles- 51k!!**

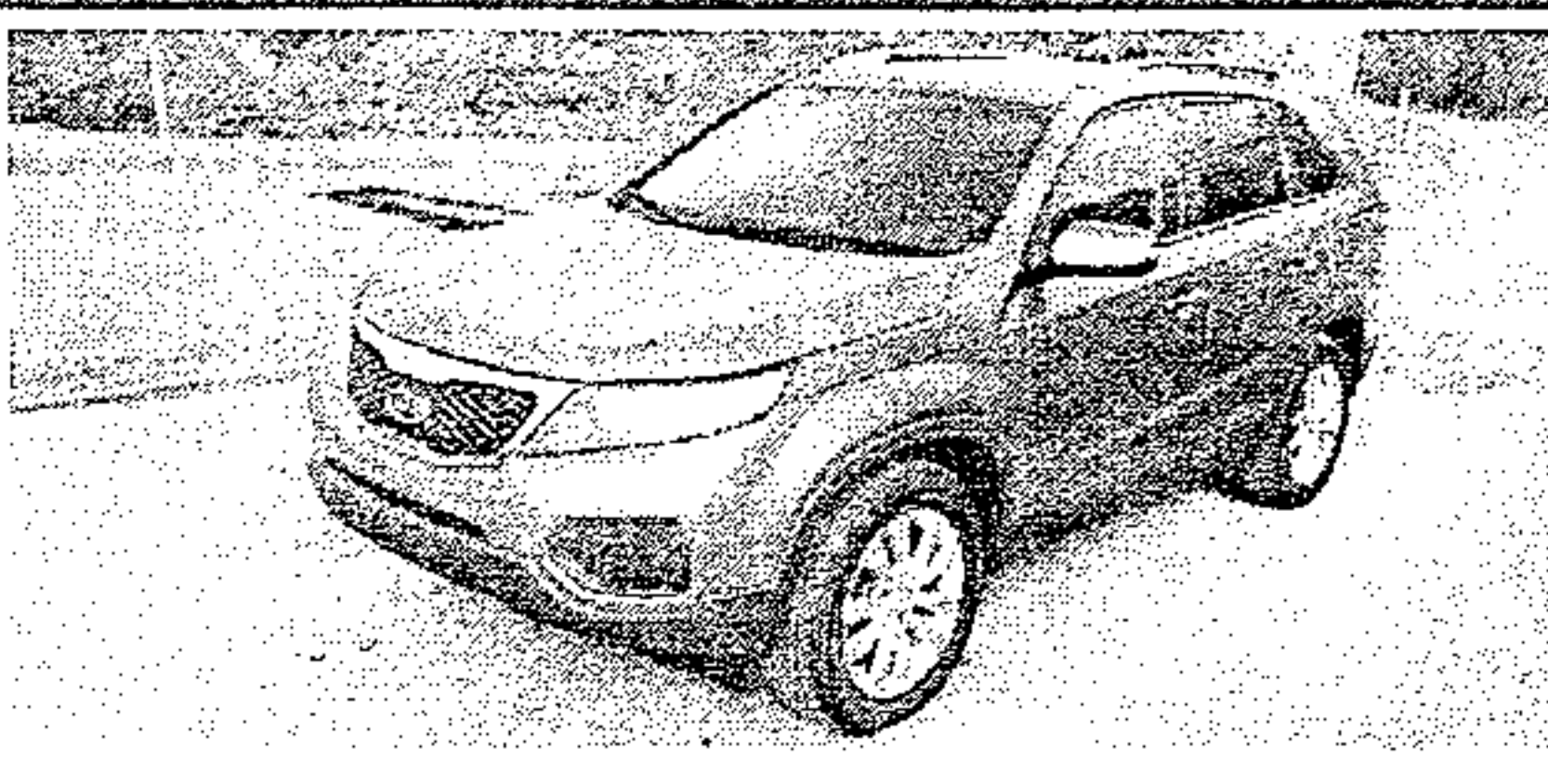

**2011 Kia Sorento Spacious, 3rd Row Seat, Alloy Wheels, Sat. Radio, Luggage Rack.**

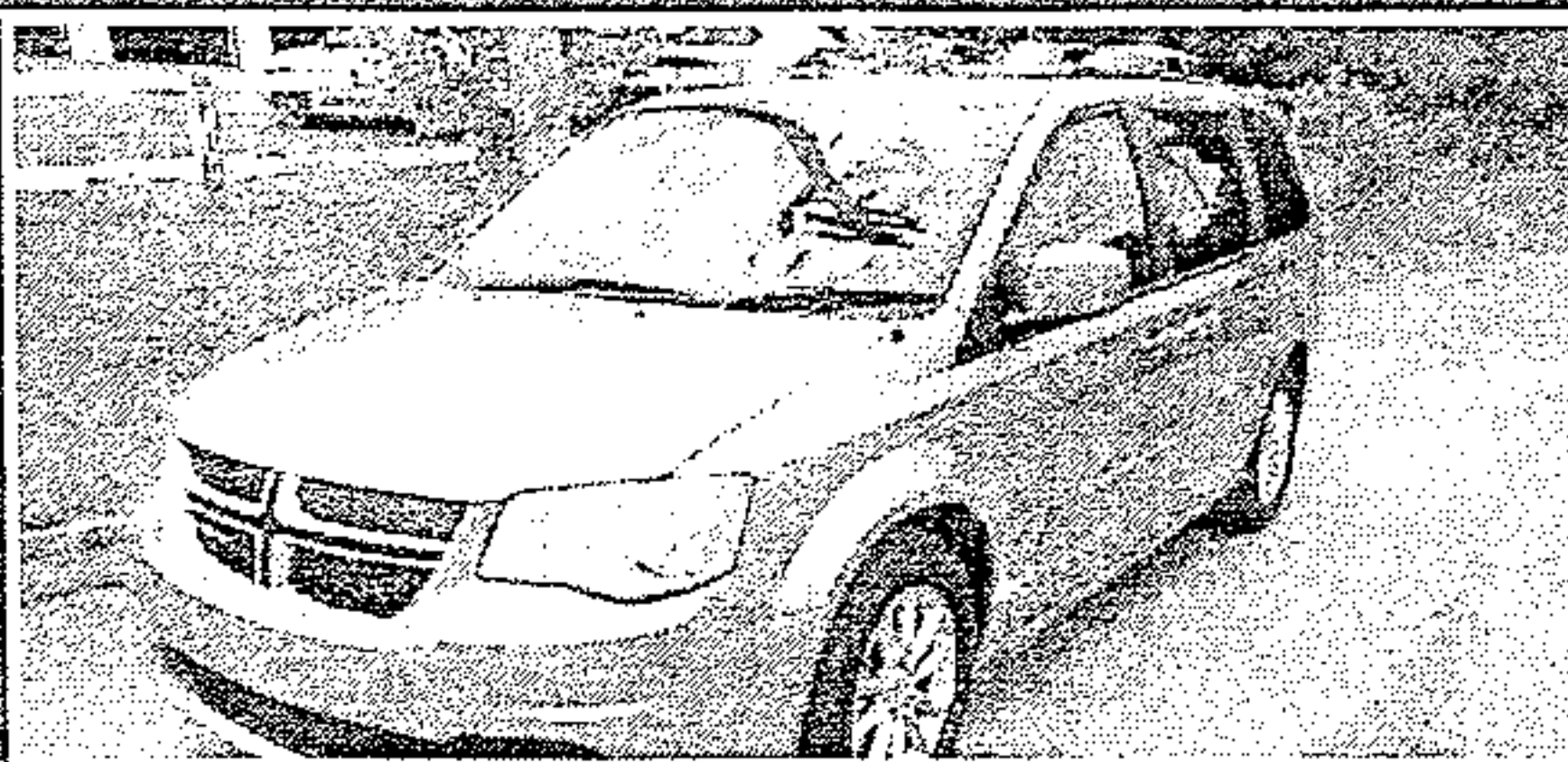

**2011 Dodge Grand Caravan DVD, Stow & Go, Loaded, Remote Doors, Rear A/C**

**DEPENDABLE MOTORS 986-9343**

**803 E. Broadway • Lenoir City**

*Serving Loudon County for 20 Years*

\* WAC. See Dealer for details

Visit our website at: [www.dependablemotorslc.com](http://www.dependablemotorslc.com)

bum

Bradley Buscher, 31, Fair Street Sweetwater, was charged with Contraband in a Penal Institution, Driving on Revoked License, Simple

Possession, and Tampering/Fabricating Evidence.

Deputy Kevin Dailey LCSO, observed a green Jeep Cherokee at Mulberry St and Carter St going 36 mph in a 30 mph zone with stationary radar with a clear audible tone. Deputy then observed the vehicle make a quick maneuver into the back parking lot of Foothills Federal Credit Union to obscure his view. As Deputy came around the corner the driver was jumping into the back seat as the passenger was moving laterally into the drivers seat.

Contact was made with both subjects where Deputy came in contact with the driver Bradley Buscher who dis-

patch advised was revoked. subject into custody Deputy observed him digging behind nervous through the entire his back. Deputy asked the investigation after taking the

(see bum ctd. pg. 7)

**For Sale: oak Wood Mulch**

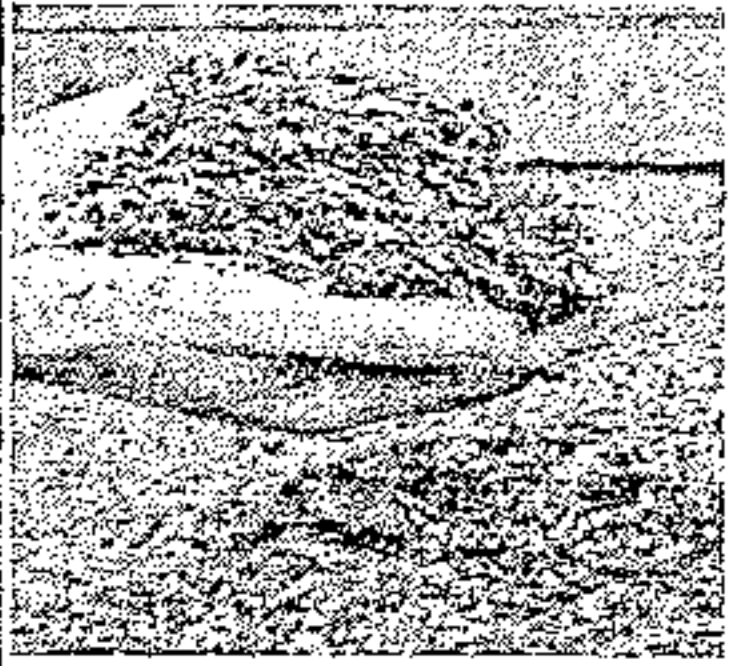

Mushroom Compost Topsoil.

**Firewood**

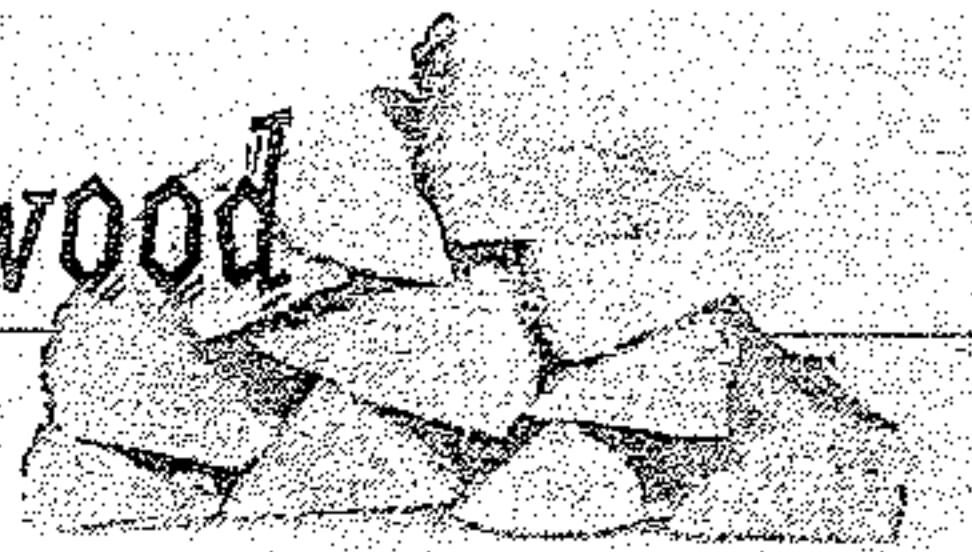

Call Steve Spoon  
**986-4282**

**C&C Lawn Care**  
Mowing, Mulching, Trimming, Edging, Clear Debris  
Free Estimates  
Call Chad 865-271-8070

**West End Storage & Warehouses**  
502 Ward Avenue • Loudon  
Call 865-458-4774 or 865-679-5555

**STAINED INK**  
**TATTOO & PIERCING**  
LENOIR CITY 865 816-6440  
NEW OWNER • NEW ARTIST • SINCE 2011  
521 Hwy 321 next to Vape & Stuff & Inn Of Lenoir!  
Clean-Affordable-Quality-Custom  
Tattoo's You've Always Wanted!

BRING IN THIS AD FOR **\$25 OFF!**  
NEW INK FOR NEW CUSTOMERS ONLY!

Check us out on FB.com/  
Stained.Ink.Tattoo/  
[www.STAINEDINK.com](http://www.STAINEDINK.com)

**C&J Towing and Recovery**  
LOWEST TOWING RATES AROUND!!!

Have you been overcharged for any type of towing service in the Lenoir City area? If you have a breakdown or accident please OWNER REQUEST C&J Towing with the officer. Also please call your Sheriff and ask him to place C&J Towing on the "Rotation List\*" and help other motorists save as much as you did! We at C&J are locally owned and operated, State approved, licensed, bonded and insured. Call and let us know if your denied service or how we can be of assistance.

\*note: the "Rotation List" is a list of wrecker services that provide service for wrecks, DUI's, breakdowns, etc. and are on an on-call basis for service. This list is approved by the Sheriff.

Cliff Teeters • Owner  
865-809-1661

**BIMBO'S**  
Deli Open 24 Hours  
865-986-9643 Call Ins Welcome  
Specials  
Lg. Cold Sub, bag of chips and 16 oz. fountain drink  
only \$6.29  
Footlong Corn Dog \$2.59

**VCAP**

unmistakable.

More than a decade ago, analysts for the FBI's Violent Criminal Apprehension Program (ViCAP)—the only national database of serial crimes—began to see a marked increase in the number of bodies recovered along the side of the road. A majority of the victims were truck-stop prostitutes, and it turned out that many of the suspects were long-haul truckers. "We had an inordinate number of victims and offenders from this rather specific population pool," Palazzolo explained.

To make matters worse, these cases are extremely difficult to investigate. A long-haul driver can pick up a prostitute at a truck stop in Georgia, rape and murder her, and dump her body on the side of the road in Florida later that day. The victim has no connection to the area where she was found, and there may be no forensic evidence to collect because the crime was committed hundreds of miles away. The lo-

cal police detectives investigating the case might have little experience dealing with a crime of this nature and may be faced with few, if any, leads.

To raise awareness among law enforcement agencies—and the public—about highway serial killings, and to focus ViCAP resources on helping to solve these cases, in 2004 the FBI began the Highway Serial Killings (HSK) Initiative, with support from the trucking industry.

"We want to help local law enforcement agencies tie their cases to similar cases nationwide," said Palazzolo, who has been managing the initiative for the past four years. "That's where ViCAP comes in, because the database can make those connections."

Without ViCAP—part of the FBI's National Center for the Analysis of Violent Crime—local law enforcement agencies investigating one of these cases may have no way of knowing a murder in their jurisdiction is similar to killings committed elsewhere.

Since the initiative began, ViCAP analysts have compiled a list of more than 750 murder victims found along or near U.S. highways, as well as nearly 450 potential suspects.

The analysts also began to develop detailed timelines on many of the suspects. The information in the timelines, obtained from company logs, gas station receipts, and other records, helps investigators pinpoint where a suspect was when murders were committed.

"It's not unusual for a driver to pass through

five or even seven states in one day," Palazzolo said. "The amount of ground they cover and the lack of any connection to where they're passing through makes it difficult to tie cases back to them."

So the timelines become crucial to investigations. The goal for ViCAP analysts is to obtain as many records from as many sources as possible to determine a driver's whereabouts at fixed points in time. "Those details are what ultimately will help tie the suspect back to the

murders," Palazzolo said.

The database is constantly monitored for cases that meet the HSK criteria. When cases are identified, ViCAP analysts can provide information to local law enforcement agencies regarding these cases—anything from timeline data to advice on what records to subpoena to suggesting a point of contact at another police department with similar cases.

In the 12 years since its creation, the Highway Serial Killings Initiative has helped many local police departments solve violent sexual assaults and murder cases, but Palazzolo cautioned that many more victims demand justice.

(see VCAP ctd. pg. 7)

## Public Notice

### Personnel Committee Meeting

The City of Lenoir City Personnel Committee will meet at City Hall, in the small conference room, on Wednesday, May 11, 2016 at 9:00 A.M., as well as Thursday, May 12, 2016 at 2:00 P.M. The purpose of the meetings will be to consider filling vacancy for the Event Center Director.

Thank you.

**Kelley's  
Tree  
Service**  
Free Estimates  
Fully Insured  
865-414-3014

**BUDGET**  
*Transmissions*

302 S. Northshore Drive Knoxville  
(865) 584-4391 [budget-transmissions.com](http://budget-transmissions.com)

**Why Buy From Budget?**  
Free Towing From Lenoir City  
or Loudon County  
20 Years of BBB Zero Customer  
Complaints Award Member  
A+ Plus Rated  
Huge Transmission Inventory  
Best Technicians Period!!!  
Call (865) 584-4391 Today!





**The Collision Center Inc.**, is locally owned and operated by Stan Ledbetter and Jake Tillett. Along with their staff, they have over 136 years of combined experience in the collision repair business.

After working for *Knoxville Collision Center* for years before it was sold to an out of state corporation, Stan and Jake have fulfilled their dreams of owning and running their own shop.

"We are a family of past co-workers who have been together for 15 years. We support ALL our military and are ALL VOL! Stop by and see us and you will know with us *"Quality is not an option it is the only standard we will accept."*

The Collision Center, Inc.  
10439 Lexington Drive  
Knoxville, TN  
865-288-7919

**Collision  
Center**  
865-288-7919

stop

Deante Childress, 35, Northland Drive Ohio, was charged with Man/Sell/Del/Resale SCH. II, Tampering/Fabricating with Evidence, and Resisting Arrest.

Donte Thomason, 41, Cleinview Ave Ohio, was charged with Man/Sell/Del/Resale SCH. II.

Sgt. Jerramie Bowen LCSO, clocked a vehi-

cle on I-75 near the 72 mile marker at 77 mph in a 65mph zone. Deputy then made a traffic stop on the vehicle at Hwy 321 at the Sprint store just off exit 81 of I-75 north. Deputy then made contact with the driver later identified as Anthony Harris. When Mr. Harris rolled down the window Deputy could smell a strong odor of Marijuana coming from the

vehicle. Deputy then asked Mr. Harris where he was heading to and he stated he was on his way to Cincinnati Ohio and that he had been to Atlanta Georgia. He stated that he had arrived in Georgia on Saturday and left this morning. Deputy then spoke to the back seat passenger later identified as Deante Childress. Mr. Childress

stated that he was also en route to Cincinnati and that they had went to Atlanta on Friday. He stated his girlfriend had rented the vehicle for him.

As Mr. Childress was walking toward Deputy patrol unit he did notice a large bulge in his pants. Deputy did ask to pat him down and when he did he asked him what was in his

pants he stated it was marijuana as Deputy went to detain him to retrieve the bag he took off running and threw the bag and Deputy could not locate the bag. Deputy Everett did take Mr. Childress into custody after a brief foot pursuit. Deputy then notified Lt. Paul Curtis. During the search of the vehicle Deputy did find a large amount, approximately 248 grams, of a white powder substance believed to be cocaine in the back floorboard behind the drivers seat. A further search of the vehicle Deputy did locate a shoe in a black bag in the trunk area. Deputy did find a small round container with white powder substance believed to be cocaine.

Investigator Ezell with the narcotics unit did field test this powder and it did test positive for cocaine. the subjects in the vehicle stated they did not know anything about this.

Mr. Childress did have approx \$701.00 that was seized for Manufacture sell and Delivery of a controlled substance (cocaine). Mr. Thomason also had approx. \$250.00 that was seized for the same charge.

All subjects were transported to the Loudon County Jail. This did occur in Loudon County. Sgt. Jerramie Bowen LCSO, made the arrest.

# PURDY'S AUTO PARTS AND SALVAGE

WE BUY SCRAP IRON • COPPER • BRASS • ALUMINUM

**\$** **Paying Top \$\$\$**  
Call For Latest Prices

*You Name It, We Buy It!*

*Radiators, Wheels, Batteries, Appliances, Farm Equipment*

**Copper**

**Paying Top \$\$\$**

**Call For Latest Prices**

**You Call We Haul!**

**423-519-5402**

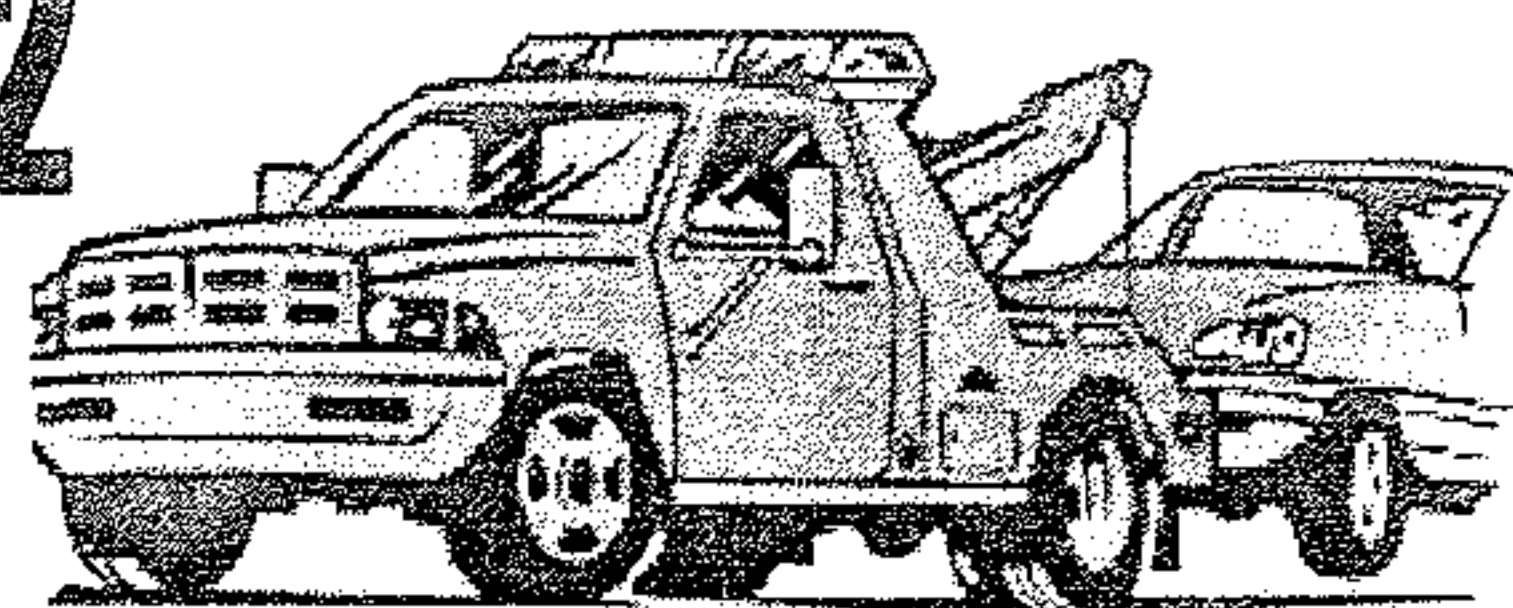

Prices subject to change with the market.

**423 337-3977**

**149 County Road 323 Sweetwater**

**Complete Cars**  
per 100 lbs.

**Scrap Metal**

**Paying Top \$\$\$**

**Call For Latest Prices**

per 100 lb

**We Buy Batteries**

**Aluminum Cans**

**Paying Top \$\$\$**

**Call For Latest Prices**

**Now Selling  
Aftermarket  
Body Parts at  
Discount Prices**

Prices subject to change with the market.

VCAP ctd. from pg. 4

And these highly mobile killers are not going to disappear.

"According to the Department of Transportation," she said, "the number of truck drivers on the road in the next 20 years is going to grow exponentially. So if we've already identified a population from which we are getting a significant number of offenders, and if we are going to be seeing more and more trucks on the road, the potential for additional highway serial killings is definitely there."

National Center for the Analysis of Violent Crime

The Violent Criminal Apprehension Pro-

gram (ViCAP) is part of the FBI's National Center for the Analysis of Violent Crime (NCAVC). The primary mission of the NCAVC is to provide behavioral-based investigative support to the FBI, national security agencies, and other federal, state, local, and international law enforcement involved in the investigation of unusual or repetitive violent crimes, threats, terrorism, cybercrimes, public corruption, and other matters.

The NCAVC consists of five Behavioral Analysis Units (BAU), each of which offers investigative and operational support to complex and time-sensitive crimes in distinct

areas:

- BAU-1: National security matters, including counterterrorism, arson, and bombings

- BAU-2: Threat assessment, cyber crimes, and public corruption

- BAU-3: Crimes against children

- BAU-4: Crimes against adults/ViCAP

- BAU-5: Research, strategy, and instruction.

bum ctd. from pg. 2

subject multiple times if he had something on him in which he replied no. He was transported to the Loudon County Justice Center where he was asked again if he had anything on

him by jail staff prior to him entering the jail in which he stated no. Once inside the jail during strip search of the subject revealed that he had synthetic urine on him, at this time Deputy entered the room with Deputy Rhymer where Deputy observed 3 Suboxone strips sticking out of his butt. Two

of the Suboxone strips were unopened with one being open with 2 unused Suboxone strips inside. Mr. Bruscher is charged with Simple Possession, Driving on Revoked, Tampering with Evidence and Introduction into a Penal Facility. Deputy Kevin Dailey LCSO, made the arrest.

## Public Notice

There will be a special called meeting of the Loudon County Capital Projects Committee on Thursday, May 12, 2016 at 4:00 PM to review Capital Funding request for next fiscal year.

# LOOK! \$75 Weekly Payments LOOK!

MARTY'S AUTO SALES • 986-2222 • MARTY'S AUTO SALES • 986-2222 • MARTY'S AUTO SALES • 986-2222 • MARTY'S AUTO SALES • 986-2222 • MARTY'S AUTO SALES •

Bad Credit  
Divorce  
Fixed Income  
Repos  
Bankruptcy  
No Credit

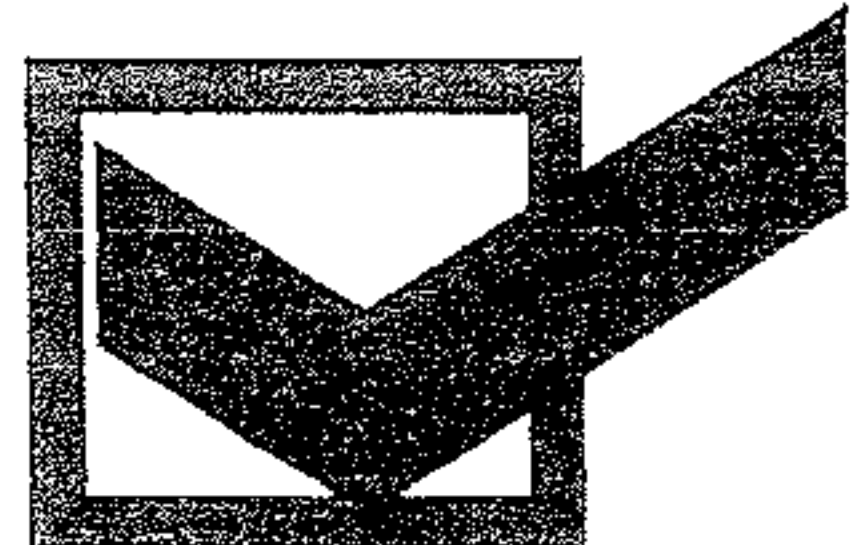

# APPROVED!

# NO CREDIT CHECKS

Visit Us On The Web At:  
[martysautosales.net](http://martysautosales.net)

**\$799 down\***

**04 Envoy, 3rd row, Runs Great Only \$799 down \***

**\$199 down\***

**04 Neon, Auto, Runs Great, Only \$199 down\***

**\$199 down\***

**02 Spectra, auto, Runs Good, Only \$199 down \***

**\$799 down\***

**05 XL7, auto, 4x4, NICE!!! Only \$799 down \***

**\$599 down\***

**05 Trailblazer, auto, good miles Only \$599 down \***

**\$199 down\***

**01 Camry, auto, cold AC, Only \$199 down \***

**\$499 down\***

**03 Santa Fe, auto, V6 Only \$499 down \***

**\$699 down\***

**09 Focus, auto, Nice only \$699 down \***

**NO Credit Checks**

**Marty's Auto Sales**  
**986-2222**

Se Habla Espanol

**100% Approval\***

\*See Dealer for details. All down payments plus tax, tag, title and fees.

MARTY'S AUTO SALES • 986-2222 • MARTY'S AUTO SALES • 986-2222 • MARTY'S AUTO SALES • 986-2222 • MARTY'S AUTO SALES • 986-2222 • MARTY'S AUTO SALES •

Lifesaver county wide. Drill scenarios will include both land and water incidents.

The Project Lifesaver program provides a tracking system to locate individuals who have a tendency to wander and become lost, usually Alzheimer and dementia patients or autistic children. Individuals that are enrolled in the program wear a bracelet on their wrist or ankle that emits a radio signal. When that person wanders they are located using receivers

that pick up the signal. The signal is specific and personalized for each individual. There are currently 10 participants enrolled in Project Lifesaver in Loudon County, ranging from children or young adults with special needs to older adults with Alzheimer's disease. The existence of Project Lifesaver in Loudon County relies on donations to purchase tracking equipment, transmitters, maintenance, and provide training for responders.

**Is Your Washer Broken?**

Call Me

I Only Charge \$100 Period!!!

Call Allen

865-617-7113

A Name You Already Know And Trust Just Got Even More Dependable  
**DEPENDABLE AUTO SERVICE, LUBE AND TIRES**  
 is Now Offering  
**Expert, Affordable Transmission Service**

All ASE Certified Technicians

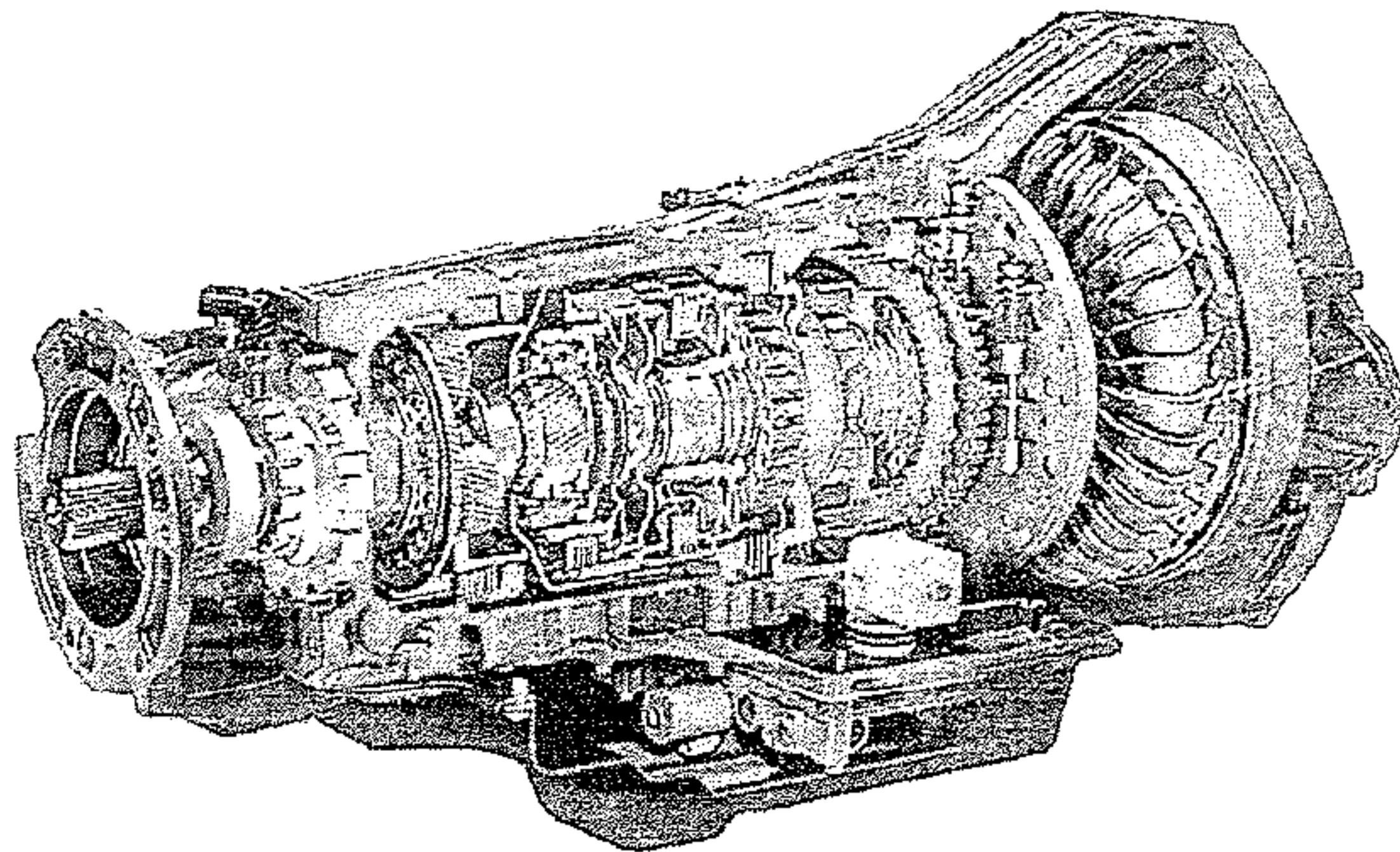

We proudly welcome all New Customers and Former Advanced Transmission Customers with a 10% Discount and Any Transmission Service or Repair\*

865-986-9359

865-986-5050

**Bad Credit, No Credit OK!!! We Finance Everybody!!!**  
**Low Down Payment!!! We Are The Bank!!!**

Over 100 Cars, Trucks & Vans in Stock - Warranties On ALL Vehicles Sold!!!

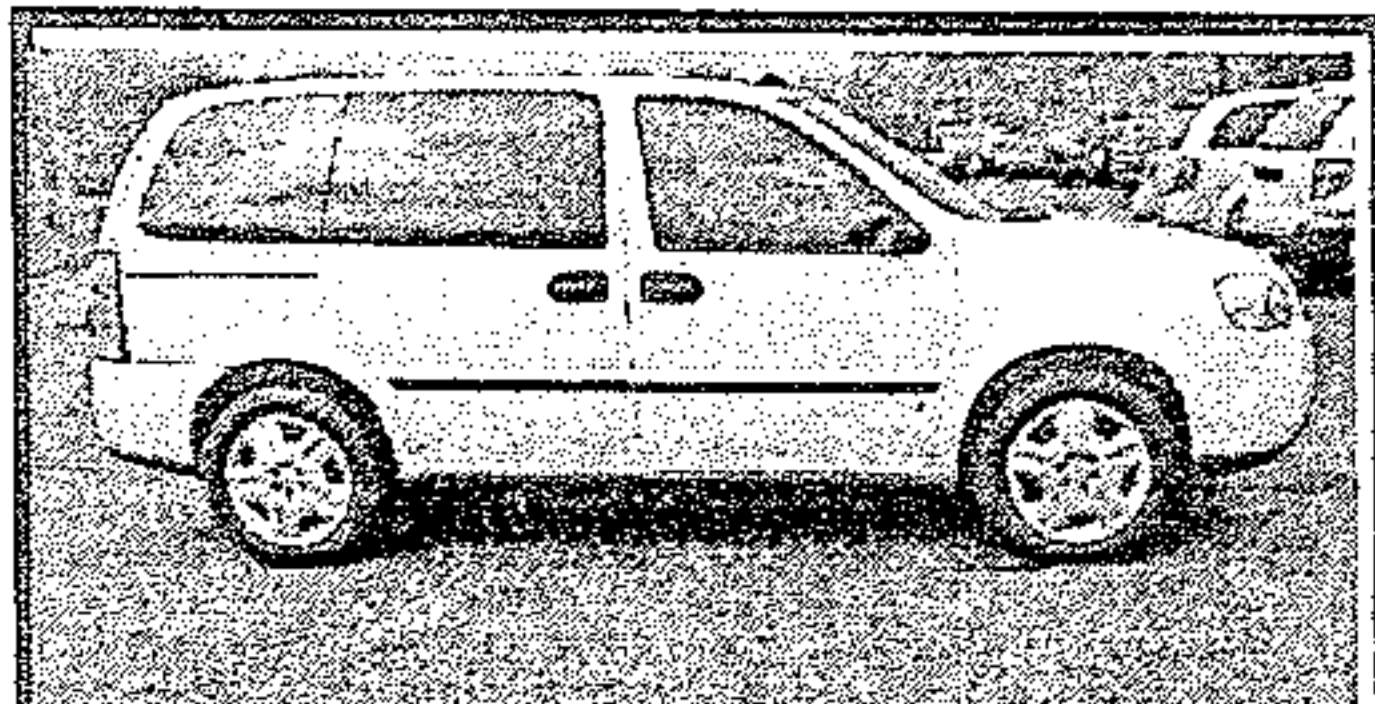

2007 Chevrolet Uplander, 60k miles, NICE!!!

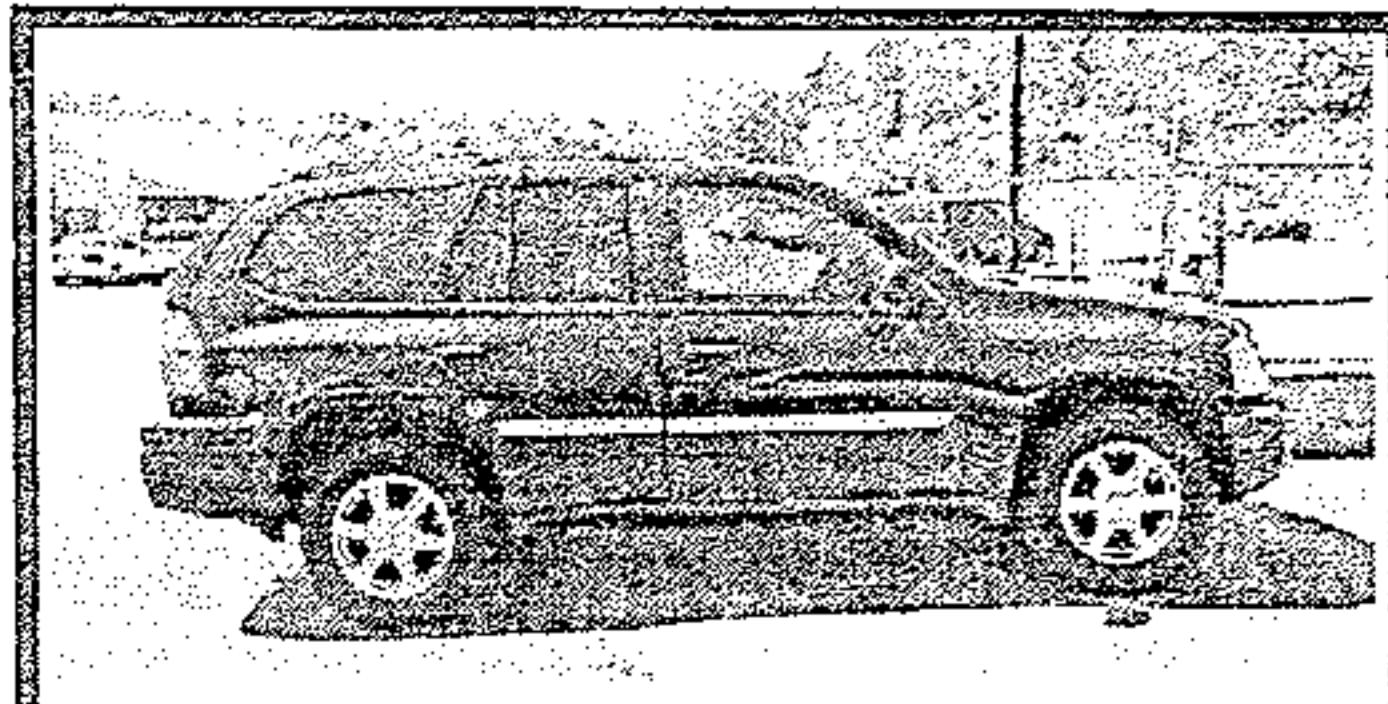

2008 GMC Envoy, Nice Clean, Great Mileage

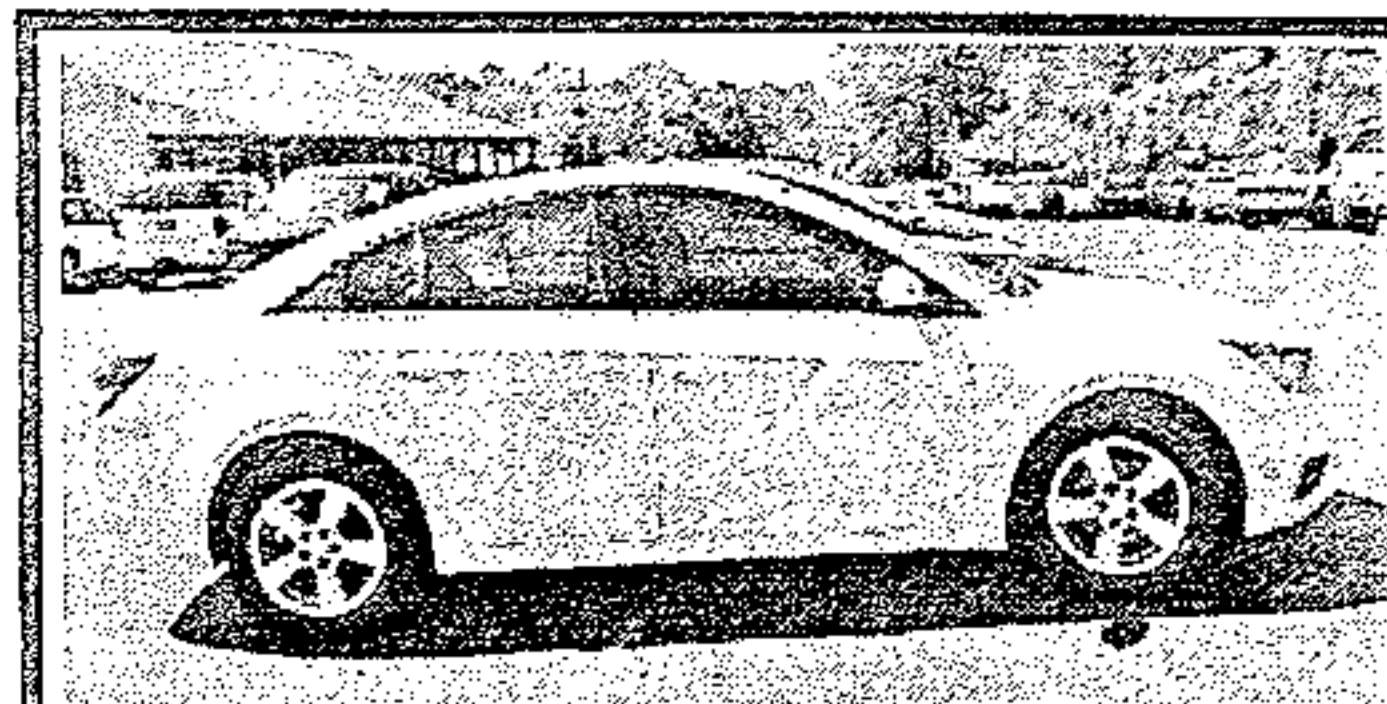

2012 Chevrolet Cruze, Great Gas Saver, Extra Clean

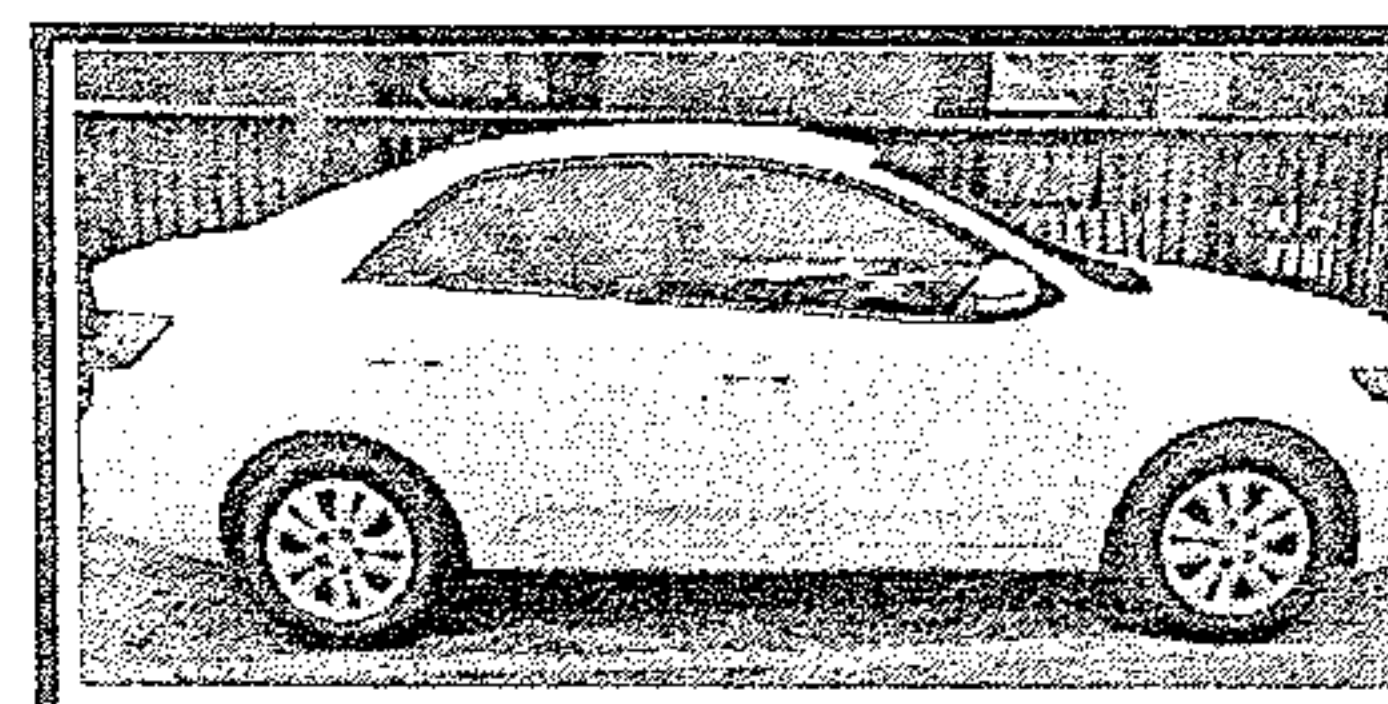

2012 Kia Forte, GAS SAVER, loaded, Nice Ride

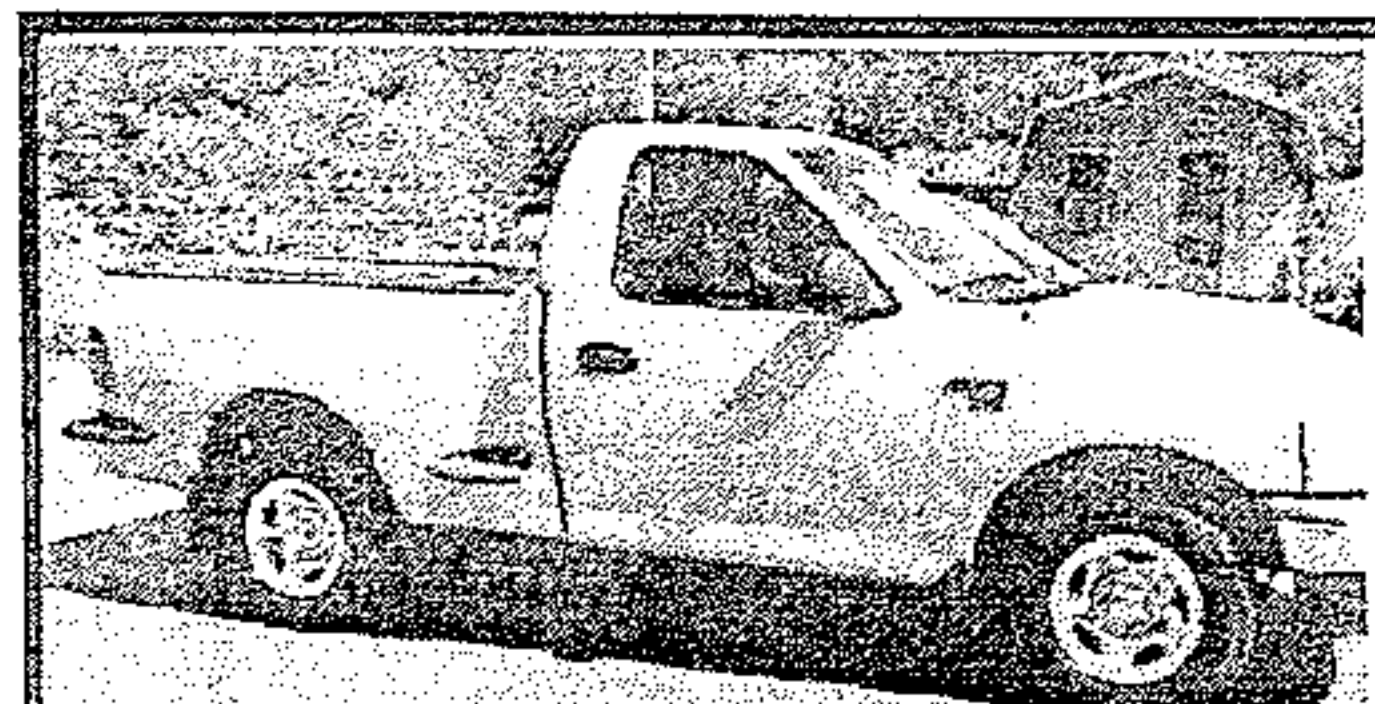

2003 Ford F150 Big Orange Special! Super Nice Truck!!!

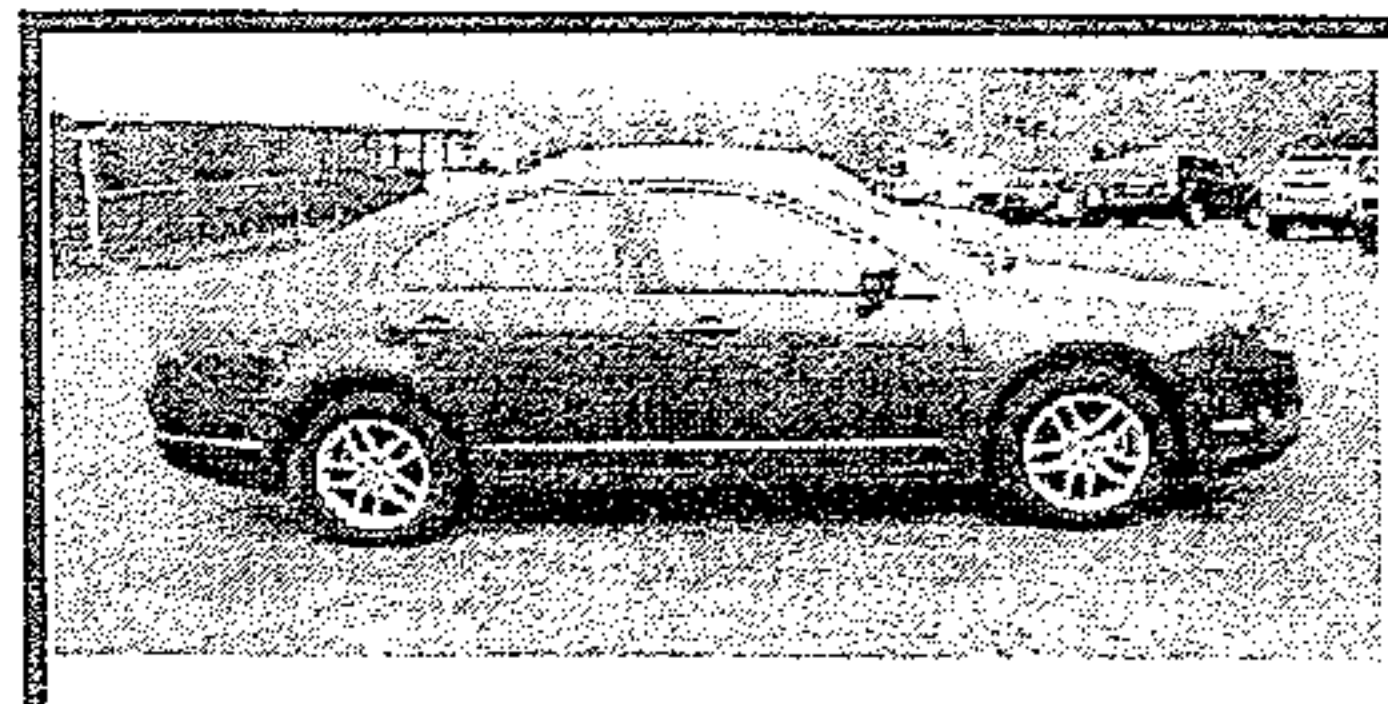

2012 Ford Fusion, Great MPG, smooth ride

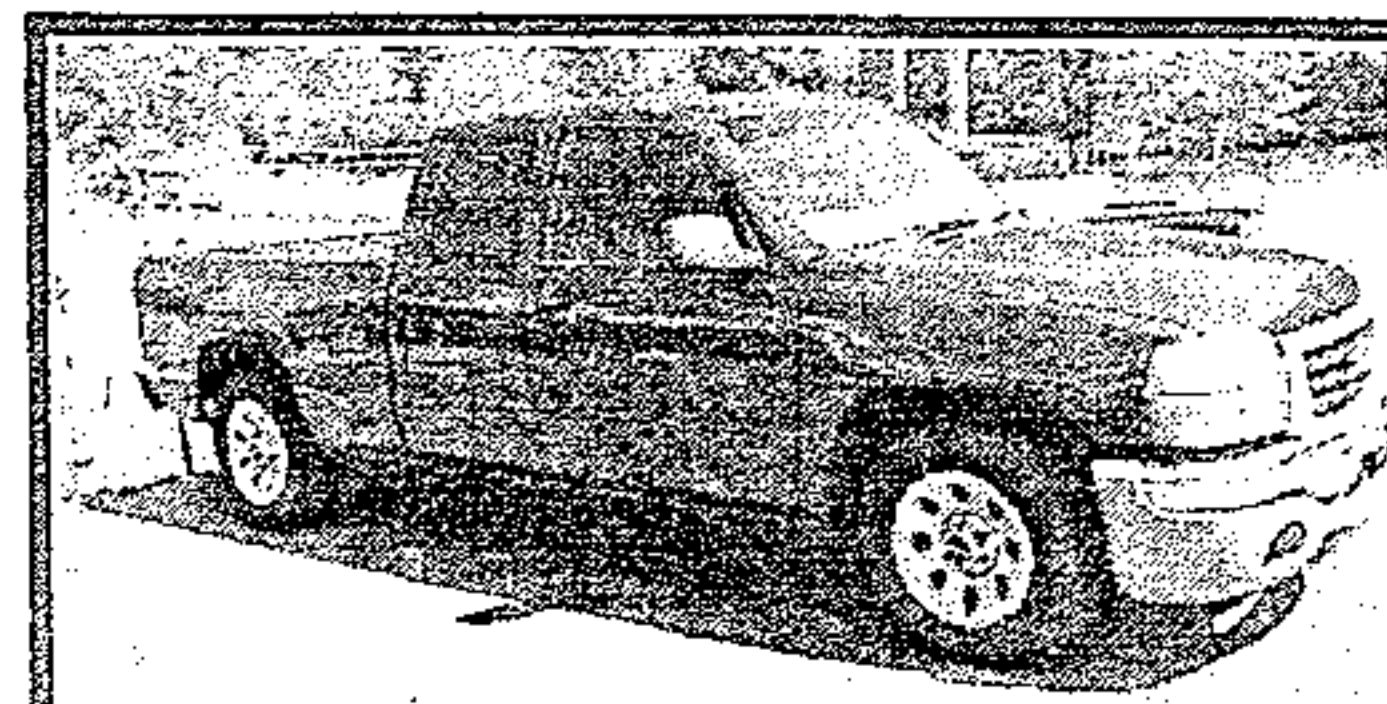

2005 GMC Sierra 1500, XCab, LWB, Nice Truck

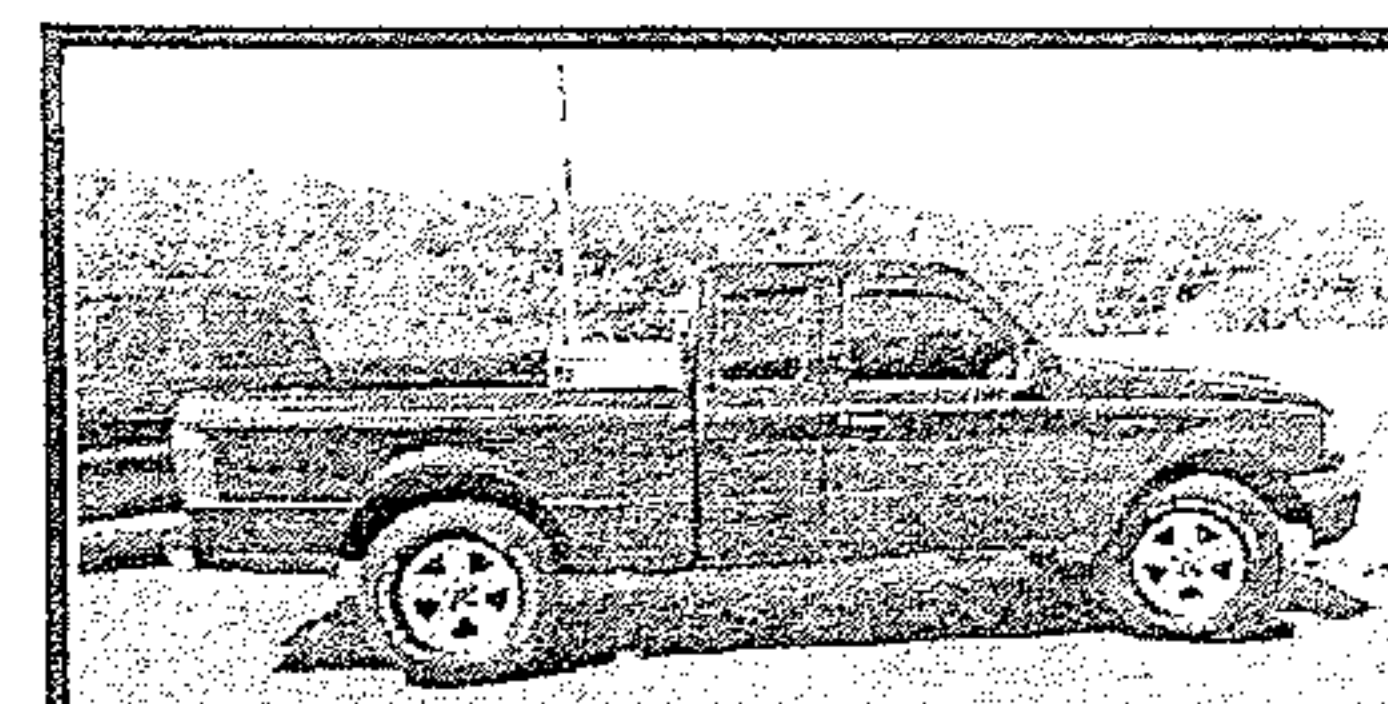

2004 Ford Ranger, Nice Loaded, Extra Clean

**WALT WILLIAMS, INC.**

\*with approved credit

3003 Highway 11 Lenoir City, TN 865-986-1111